

Serie

PR45-140 T Series

Serie di ventilatori a pale curve rovesce in esecuzione 12.

Versioni:

Standard: coclea costruita PP - girante costruita PP/INOX/Fe ebanitata - carpenteria in lamiera di acciaio verniciato polveri - viteria acciaio INOX

ATEX: coclea costruita PP-el conduttivo - girante costruita PP-el/INOX/Fe ebanitata - carpenteria in lamiera di acciaio verniciato polveri - viteria acciaio INOX

Fans series with backward curved blades - ex. 12.

Versions:

Standard: PP welded housing - PP/INOX/Fe+ebonite impeller - epoxy painted frame - stainless steel screws

ATEX: PP-el antistatic welded housing - PP-el/INOX/Fe+ebonite welded impeller - epoxy painted frame - stainless steel screws

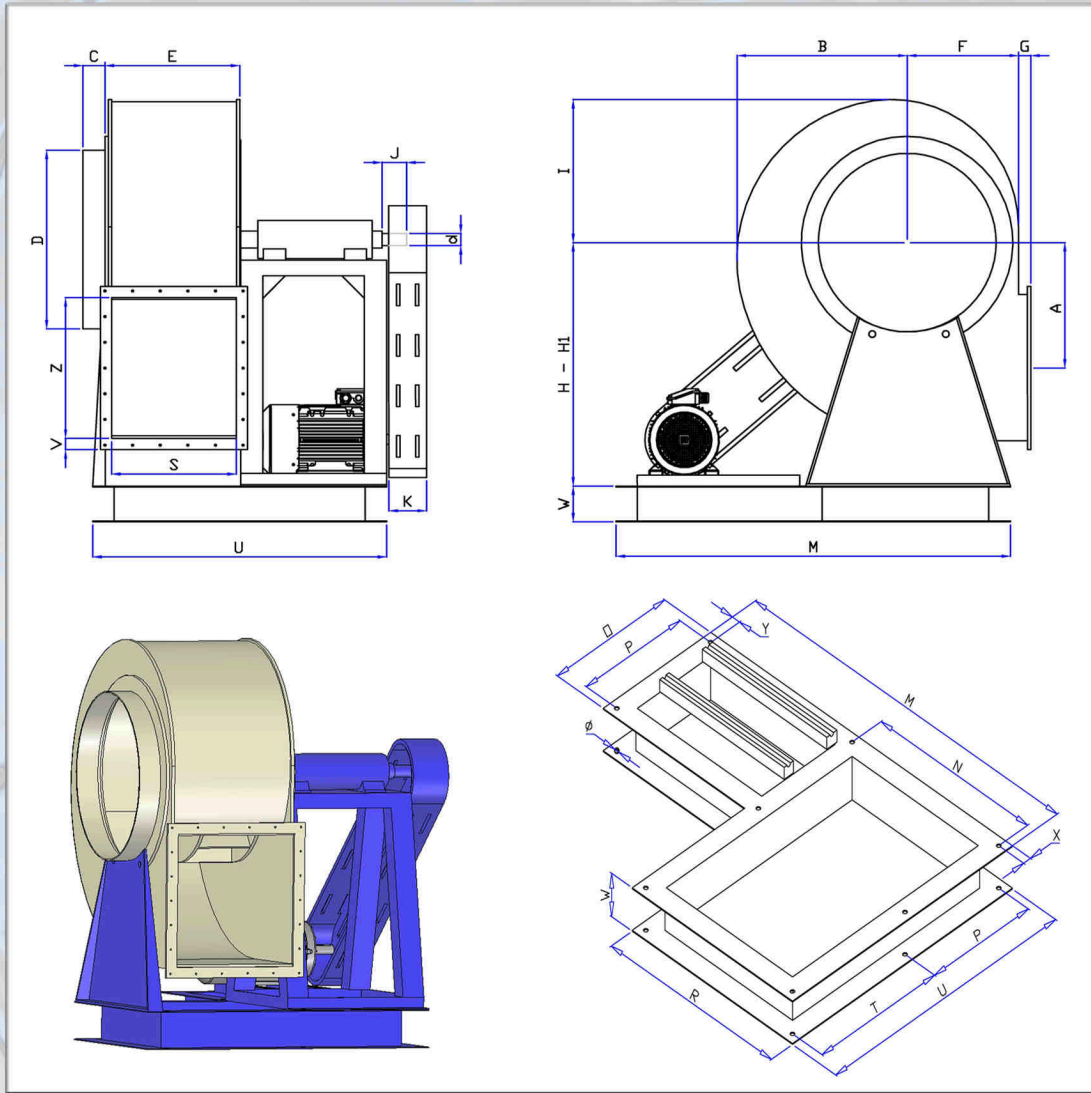

Tipo Type	A	B	C	D	d	E	F	G	H	HI	I	J	K	M	N	O	P	R	S	T	U	V	W	X	Y	Z	Ø	KG.*
PR45T	324	410	60	355	38	295	310	50	550	-	360	90	160	1030	370	400	340	-	265	-	-	40	120	25	25	355	16	130
PR50T	360	480	80	400	42	380	330	50	630	-	400	110	160	1050	365	530	480	415	350	350	880	50	140	25	25	400	16	190
PR56T	410	550	80	450	48	430	385	65	710	-	450	110	160	1365	635	530	480	685	400	410	940	50	160	25	25	450	16	232
PR63T	445	610	80	500	48	490	416	65	800	-	500	110	160	1365	635	530	480	685	450	410	940	50	160	25	25	500	16	252
PR71T	500	690	100	700	48	545	440	75	850	700	570	110	185	1540	772	629	551	850	500	560	1299	60	160	40	40	560	20	460
PR80T	560	790	100	800	55	605	500	75	950	780	650	110	185	1720	862	629	551	940	560	690	1319	60	160	40	40	630	20	516
PR90T	630	870	100	900	55	680	590	75	1060	870	720	110	185	1890	962	629	551	1040	630	760	1389	60	180	40	40	710	20	610
PR100T	710	985	120	1000	65	770	660	75	1180	980	840	110	206	2094	1056	685	607	1134	710	840	1525	70	180	40	40	800	20	805
PR110T	820	1080	150	1100	80	870	750	100	1320	1100	930	140	250	2318	1180	838	760	1258	800	960	1798	70	200	40	40	900	24	1050
PR125T	920	1210	150	1250	80	970	840	100	1500	1200	1020	140	300	2488	1350	838	760	1428	900	1050	1888	80	220	40	40	1000	24	1200
PR135T	1020	1350	150	1350	90	1080	875	125	1700	1350	1120	160	300	2758	1450	838	760	1528	1000	1140	1978	80	220	40	40	1100	24	1400
PR140T	1020	1350	150	1400	90	1080	875	125	1700	1350	1120	160	300	2758	1450	838	760	1528	1000	1140	1978	80	220	40	40	1100	24	1400

* motore escluso / completo di basamento - without motor / with base frame

PESI ORIENTATIVI - APPROXIMATE WEIGHTS

Venplast srl